

# Digital Linearizer for RF Amplifiers

Sante Andreoli\*, Howard G. McClure\*\*

\* Itelco, R&D - RF Signal and Digital Design. Manager  
Via dei Merciarì I-05019 Orvieto (TR) - Italy

\*\* Itelco USA, Vice President, North American Operations  
9035 Wadsworth Parkway, Suite 4450, Westminster,  
CO 80021 - USA

e-mail: itelco.rd@krenet.it - mcclure@itelco-usa.com

Paolo Banelli, Saverio Cacopardi

Istituto di Elettronica - Università di Perugia

Via G. Duranti 1/A - 06125 Perugia - Italy

e-mail: banelli@istel.ing.unipg.it - cacopardi@istel.ing.unipg.it

**ABSTRACT** Broadcast technology is at the beginning of a new era. It is characterized by the intensive use of the most advanced digital modulations formats (8VSB, QAM, OFDM) in combination with high power RF amplifiers. To date the linearity required for these digital formats has only been accomplished in cumbersome low efficiency class A amplifier or even more cumbersome feed-forward systems. A potentially more efficient and cost effective approach is the combination of non linear power amplifiers and a predistortion technique capable of compensating for the non linear amplifiers. Digital predistortion will provide a highly linear output and improved efficiency. Itelco has developed a digital adaptive base band predistorter to provide for improved performance and cost. The technique is independent of the modulation type, the output frequency, or the signal bandwidth. Furthermore the capability of automatic adaptive predistortion to compensate for the environment (temperature, power supply variations, aging, and even operation during replacement of a faulty module) is highly desirable.

## I. Introduction

A new era has started in the broadcast industry and is characterized by the introduction of digital technology. This digitalization involves both the signal generation (source coding) and the modulation (channel coding).

New standards have been proposed, and almost accepted, for both video and audio transmissions:

- The Grand Alliance HDTV is now under experimental use in U.S. while the DVB standard is operational in Europe for satellite and cable TV transmissions. DVB is almost completely defined for Terrestrial TV systems.
- Digital audio transmission has already started in Europe and Canada with the Eureka-147 system and a digital system is also expected to be introduced in U.S. in the next two years.

The Grand Alliance HDTV uses the 8VSB modulation, while in Europe DVB and Eureka-147 are using OFDM. These modulations do not have a constant envelope, implying higher sensitivity to non linear distortions. This fact has a great impact on the High Power Amplifier (HPA) linearity requirements in order to achieve acceptable intermodulation distortion.

The non linearity effects on the output signal are not a new

problem: satellites, cellular, radio relay links, radar must also take into account the HPA non linearity. However the broadcast applications exacerbate this aspect due to the wide band spectra and the required high power compared with other applications.

Two kind of distortion are to be considered: amplitude and phase. Real amplifiers have a maximum output power (saturation level) and an input-output power relationship that will depart from a straight line as the output power approaches the saturation level: this is referred as AM/AM distortion. Similarly a phase shift depending on the power level will also occur, generating AM/PM distortion.

The final effect of AM/AM and AM/PM distortion is the generation of unwanted spectral energy both in-band and out-of-band. The in-band energy will cause distortion of the transmitted signal and out-of-band energy will cause ACI (Adjacent Channel Interference).

One way to reduce the effects of non linearity is to drive the HPA with a high back-off and a consequent lower power efficiency. In order to improve the efficiency and consequently reduce size and cost of the broadcast transmitters, the linearity of HPA must be increased: one solution is the use of pre-distortion techniques.

A pre-distorter is a device that generates a distortion that compensates for the HPA distortion. The result of a pre-distorter is that the HPA can operate at higher power with the same level of distortion or the same power with lower distortion.

Following are several types of pre-distortion techniques that have been proposed:

- Feed-forward [1], [2]
- Data pre-distortion with or without memory [3], [4]
- Signal pre-distortion: performed at RF, IF, or at Base-Band [5], [6], [7].

The feed-forward approach takes a sample from the amplifier output and removes the main signal leaving only the distortion products and subtracts this distortion signal from the output. This system is quite complex, requiring extra components, fine adjustments, extra power for the losses introduced on the main signal and additional power to generate the distortion signal.

Data pre-distortion is a technique that considers the data vector space (constellation), pre-distorting it in order to counteract the distortion introduced by the HPA. It only compensates the distortion at the sampling instant and it does not eliminate out-of-band distortion. Data predistortion is dependent on the

modulation type and should not be applied to complex modulations such as OFDM.

Finally, the signal pre-distortion method generates a pre-distorted signal which, when passed through the HPA, will emerge without distortion. The total effects of an ideal signal pre-distorter combined with an HPA is a linear function up to the HPA saturation level. For this reason, a signal pre-distorter eliminates both in-band and out-of-band distortions, as long as the signal does not exceed the saturation level.

Theoretically the signal pre-distortion can be realized at RF, at IF or at the Base-Band. The RF approach is not desirable because it requires a specific circuitry for each frequency band as well as alignment at that frequency and stability of the environmental parameters.

The IF and Base Band approaches solve these problems by being independent from the final frequency. They are more stable, with regard to environmental parameters, due to the lower operating frequency. The only critical aspect for these approaches is the increased linearity requirements from the pre-distorter output up to the HPA. Since the pre-distorter generates some out-of-band energy, the bandwidth of the signal increases and the intermediate stages must avoid linear distortions over a wider bandwidth up to the HPA.

ITELCO has developed its own solution based on a Signal Base Band Pre-distorter with a complete digital realization. The following are the advantages of this approach:

- The pre-distorter is totally independent from the modulation system (8VSB, OFDM, QAM, ...).
- The pre-distorter eliminates both in-band and out-of-band distortions.
- The pre-distorter is channel independent and can be used for every output frequency.
- The pre-distorter is independent from the HPA type, frequency, and power technology (Solid State, TWTA), class (A, AB, ...).
- The pre-distorter does not require extra power, extra amplifiers nor does it introduces any loss in the main signal, as in the feed-forward technique.
- The pre-distorter is completely digital resulting in a very stable product that does not require alignment or tuning. It results in a product that is totally insensitive to environmental variations.
- The pre-distorter is capable of be augmented with adaptive circuitry that does not require training or periodic sequences to become a fully automatic corrector.

## II. HPA Modelization and Predistortion

A non linear HPA can be characterised by its envelope distortion curves AM/AM and AM/PM [5]. The RF input to an HPA  $x(t)$  is expressed by :

$$x(t) = R_x(t) \cdot \cos [\omega_o t + \theta_x(t)] \quad (1)$$

The corresponding output  $y(t)$  is expressed by

$$y(t) = G [R_x(t)] \cdot \cos \{ \omega_o t + \theta_x(t) + \Psi [R_x(t)] \} \quad (2)$$

where  $G$  and  $\Psi$  are respectively the AM/AM and AM/PM

distortion curves. The distortion curves of the Itelco DAB Amplifier considered in this work are shown in Fig.1 where the axis is normalised with respect to the Maximum Output Power.

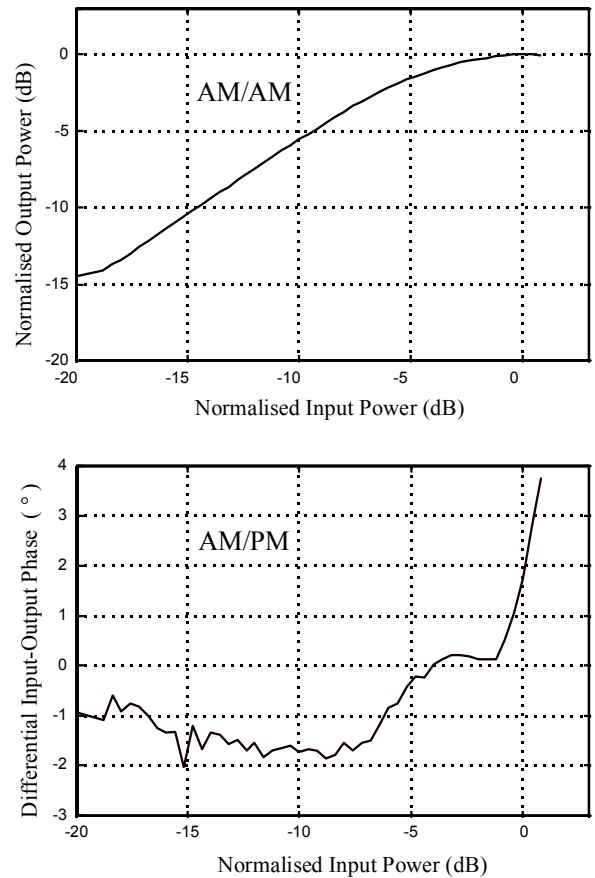

Fig. 1 Measured Amplifier Distortion Curves

A predistorting device designed to counteract the non linear distortions introduced by the amplifier, has to implement two non linear functions  $H$  and  $\Phi$  that globally invert  $G$  and  $\Psi$ . The cascade of the predistorter with the HPA gives rise to a pseudo-linear device (i.e. an ideal soft-limiting device) as showed in Fig.2, where the resulting AM/AM and AM/PM curves for the predistorted amplifier are shown.

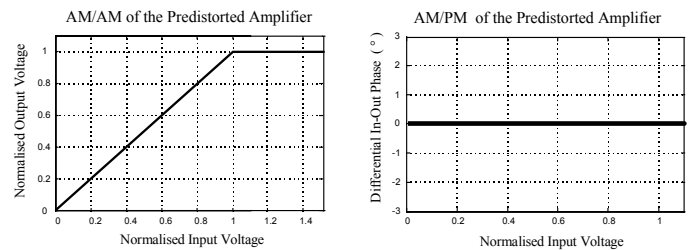
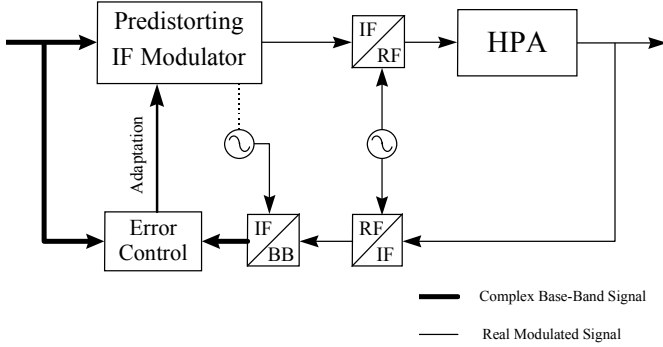

Fig. 2 Predistorted Amplifier Distortion Curves

If the amplifier exhibits non linear characteristics invariable with time, a fixed predistorting device, as previously considered, is enough to achieve good linear performance. However the amplifier distortion curves  $G$  and  $\Psi$  change in practice due to

age, temperature, power level, frequency change and so on. This means that the predistorting device has to adapt its non linear functions  $H$  and  $\Phi$  to follow the changing of the amplifier characteristics. A schematic representation of the Itelco predistorted device, including adaptivity is shown in Fig.3. The logic of adaptivity is based on the comparison of the Input to Output of the overall system : this error is used to make the predistorting curves follow the HPA non linearity variations.



**Fig.3** Amplifier with Adaptive Predistorter

### III. Signal Modulation

The predistorter performance has been tested focusing our attention on OFDM modulation even if similar considerations hold for other single carrier modulations with non constant envelope like QAM, 8VSB and so on. The results obtained for the DAB (Digital Audio Broadcasting) Transmission Mode I (briefly summarised in Tab.1) will be presented.

An OFDM signal is very sensitive to AM/AM and AM/PM distortions because of its non-constant envelope. This fact can be placed in evidence recalling that an OFDM base-band signal is expressed by [8], [9]

$$\hat{x}[k] = x_I[k] + j x_Q[k] = \sum_{n=0}^{N-1} s[n] \cdot e^{j \frac{2\pi}{N} nk} \quad k = 0, \dots, N-1 \quad (3)$$

where  $N$  is the carrier number and  $s[n]$  the  $N$  complex modulating data symbols. So, if the hypothesis of statistical independence of the complex symbols  $s[n]$  is made and if the carrier number  $N$  is high enough (i.e.  $N > 30$ ) and equal power distributed, the resulting complex signal  $\hat{x}[k]$  is amplitude Gaussian distributed over each I and Q component [10], and amplitude Raleigh distributed over the Module  $R_x[k] = \sqrt{x_I^2[k] + x_Q^2[k]}$  [11], [12], as illustrated in Fig.4a and stated in (4)

$$p(R) = \frac{R}{\alpha^2} \cdot e^{-\frac{R^2}{2\alpha^2}} = \frac{2R}{P_x} \cdot e^{-\frac{R^2}{P_x}}, \quad \text{pdf of } R_x[k] \quad (4)$$

where  $P_x = 2\alpha^2$  is the mean power of the complex base band signal  $\hat{x}[k]$ .

The important consideration arising from Fig.4 is that the envelope of the OFDM signal varies on a very large dynamic (i.e. reaching the maximum value when all the sinusoids add in phase). This implies that even if an ideal predistortion is

achieved by means of Fig.2, it will not be possible to avoid the clipping introduced on the signal envelope by the soft-limiting saturation: in practice an OFDM signal also forces the predistorted amplifier to be operated with a Back-Off from its maximum output power.

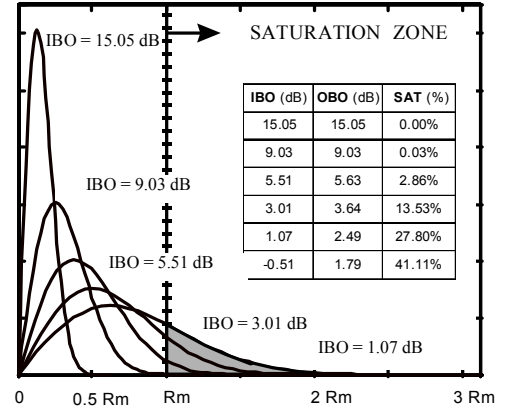

**Fig.4** Raleigh Distribution and Clipping

The Input Back-Off (IBO) for the predistorted amplifier is defined as

$$(IBO)_{dB} = 10 \cdot \text{Log}_{10} \frac{P_{\max}}{P_x} \quad (5)$$

The clipping phenomenon causes a penalty in terms of Output Power so it is easy to show that the corresponding Output Back Off (OBO) of the clipped signal  $x_{clip}$  is expressed by

$$(OBO)_{dB} = 10 \cdot \text{Log}_{10} \frac{P_{\max}}{P_{x_{clip}}} = (IBO)_{dB} - (1 - e^{-IBO})_{dB} \quad (6)$$

and the probability  $p_{SAT}$  to be in saturation zone is [11]

$$p_{SAT} = \text{Prob}\{ R > R_{\max} \} = \int_{R_{\max}}^{\infty} p(R) dR = e^{-IBO} \quad (7)$$

If the IBO is reduced the clipping phenomenon occurs frequently as illustrated in Fig.4b : consequently the non linear distortions introduced become more relevant until completely masking the action of the predistorting device.

### IV. Simulation Strategy

The proposed predistorting technique, has been computer modelled to identify its potential performance and to set the goals for the Itelco device. The results reported here take into account the project parameters and the digital components utilised in the practical predistorter. The primary parameters that influence the project performance are:

- Sample Frequency
- Bits of Signal Quantization
- RAM Requirements
- Ripple and Selectivity of the Digital Filter utilised

The results presented are based on fixed predistorting curves. The predistortion curves correspond to an adaptation algorithm

that has converged and assume the system is not disturbed

<b>DAB ( Mode I )</b>	
Number of Carriers	1536 (Active) 512 (Switched Off)
Carrier Spacing	1 KHz
Bandwidth Requirements	1.536 MHz
Modulation over each carrier	$\frac{\pi}{4}$ Shifted DQPSK
Number of samples in an OFDM symbol	2048
OFDM Symbol Duration	1.246 msec

Tab.1 DAB Main Parameters

. Spectrum Estimation of the amplifier output was chosen to characterise the predistortion performance. The graphical results reported are accomplished simulating the transmission of M consecutive DAB Blocks (each 2048 samples long). The Mean Output Spectrum is estimated by FFT, mediating the spectrum of the amplifier output corresponding to each block. Experience has shown that a number of M = 25 independent blocks is enough to statistically characterise the OFDM signal and the effects of non-linear distortions on the Power Spectrum Density. If a greater number of blocks is considered, the mean spectrum of the distorted output does not vary significantly (i.e. M = 25 is good). The amplifier output spectrum must be compliant with the proposed [13] emission mask for DAB transmitters, shown in Fig.5.

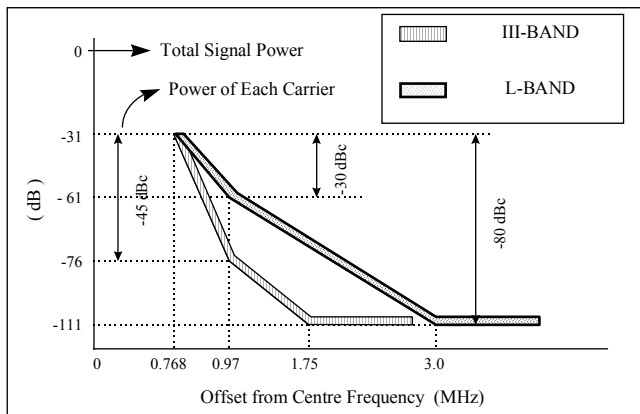

Fig.5 DAB Emission Mask

It is also noteworthy that a DAB communication system can tolerate In-Band distortions up to -25 dBc (i.e. dB from each carrier level) without a significant penalty in terms of BER as shown by laboratory tests. The results obtained by simulations can be compared both at a fixed OBO or at a fixed ACI level. In the first case the improvement provided by the predistorter is in ACI level for a fixed output power; this improvement in ACI reflects a lower cost of the RF Output Filter needed to insure the Emission Mask of Fig.5. In the second case, the improvement consists in increased output power with the same ACI level.

### V. Simulations Results

The simulations results are summarised in Fig.8 where the estimated Power Spectrum Density of the Amplifier Output (with and without the predistorter) is shown for different values of the OBO. The simulation is performed at Base Band but the HPA output of Fig.8 is represented at IF with a Central Frequency  $F_c$  equal to 4.096 MHz. The ACI level is measured at  $F_{ACI}$  (see Fig.5 and Fig.6) expressed by

$$F_{ACI} = F_c + 970 \text{ KHz} = 5.066 \text{ MHz} \quad (8)$$

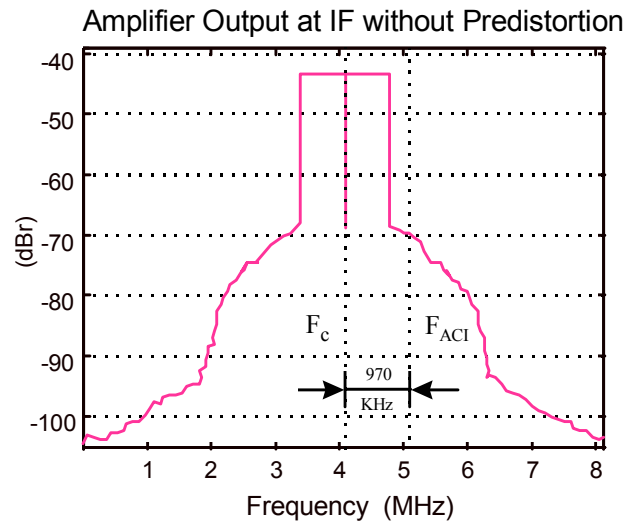

Fig.6 Amplifier Output Spectrum represented at IF

Figures 8 are an expanded view showing the spectrum of the ACI as shown in Fig.6.

Figure (a) and (b) show that the predistorting device does not yield a benefit in the In Band Distortion (IBD) for OBO value of about 3.5 dB: this is because the back-off is too small and the predistorter is driven into clipping by the OFDM signal. Figure (c) and (d) correspond to a more realistic operating configuration with the OBO equal to 6 dB: a 3 dB improvement on the IBD and a 10 dB improvement on the ACI is realised. The benefit of using a predistorting device becomes more evident if the OBO is increased : this fact arises from figure (e) and (f) where a back-off of about 7.7 dB is imposed. These results were predictable considering that it is possible to divide the non linear distortion introduced by a power amplifier in two

different categories : the first one originates by the non-linear behaviour of the AM/AM and AM/PM curves while the second depends only on the saturation imposed by the AM/AM curve. The first type of distortions can be effectively counteracted by the predistorter while the second cannot be avoided in any way. Figure (h) and (c) represent the same condition in terms of IBD of about -26 dBc: the Itelco predistorting strategy allows for an increase of about 0.5 dB of output power (12 %); at the same time a 7 dB ACI gain which allows for use of a less selective (and cheaper) RF Output Filter in order to accommodate the emission mask of Fig.5. Figure (g) shows an idealised improvement in the predistorter performance respect to Figure (h): this result can be achieved by a more expensive circuitual realisation of the predistorting strategy ; a trade-off between costs and benefits must be considered between these two implementations. Two more Figures (i) and (l) are reported to show the potential of the predistortion technique if the saturation phenomenon is avoided by an OBO value comparable with the dynamic of the input signal.

## VI. Hardware Description & Measurements

The photo shows the ITELCO Predistorting Device implemented on a single board. Two additional circuit boards will have to be implemented to accomplish the full adaptive predistorter as showed in Fig.3: one for converting the HPA RF output to Base Band, and the other for the Input-Output Error Control. The Predistorting Board of Fig.7 has been developed with an interface to accommodate the input from the Error Control Board.

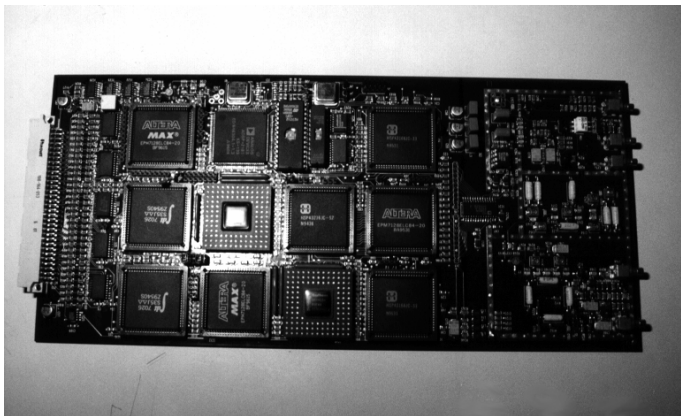

Fig.7 Photo of the Predistorter Prototype

Hereafter are also shown the Spectrum Analyser measurements of the amplifier output with and without predistorter (see Fig.7b). The predistorter has to compensate the Class A amplifier characterised by the AM/AM and AM/PM shown in Fig.1. The measurements reported in this context are referred to a 50 Watt average output power, that corresponds to about 6 dB of OBO for the amplifier. The measurements (shown in Fig 7.b)

are obtained without any RF filtering and are in good agreement with the simulation results of Fig.8. However, the output spectrum for the predistorted amplifier exhibits a better ACI improvement in the left zone than in the right one. This asymmetry should depend on the filtering stages between the baseband predistorter and the RF amplifier which need of a more careful designing to not vanish the predistorting action. Thus, we expect to obtain even better performance by the final adjustment of all the transmitting system.

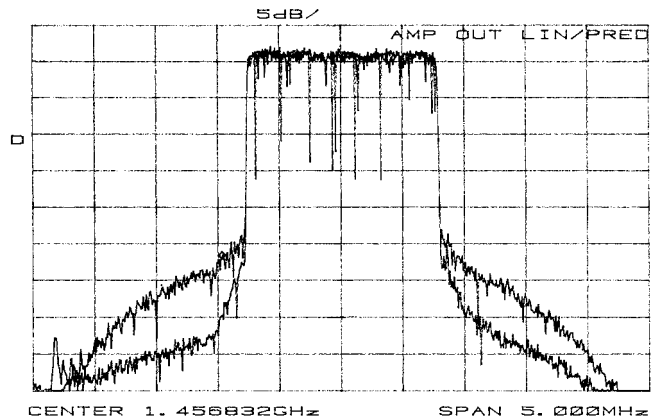
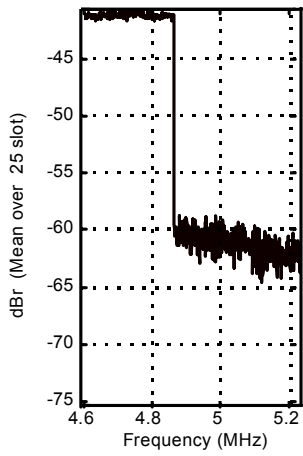

Fig.7b Amplifier Output Spectrum with and without Predistorter (Average Power =50 Watts)

## VII. Conclusions

An effective technique to counteract HPA non linear distortions has been presented: it has shown good performance for a DAB signal which is characterised by an high peak-to-mean power ratio. However it is noteworthy that the proposed approach is independent from the modulation technique as it belongs to the category of "signal predistortion". Therefore the same predistorter can be also used with DVB signals or with single carrier modulations like 8-VSB. For DVB signals the same OBO versus IMD, like for DAB, should be achievable with the appropriate changing of the predistorter working frequency. For an 8-VSB modulation lower OBO is expected for the same IMD: this is due to the lower peak-to-mean power ratio of a single carrier 8-VSB signal compared to a multi-carrier OFDM signal. The realised predistorter can therefore be seen as a general base-band stand alone device, that can operate in any transmission system: it only requires a non-distorting BB to RF chain from the predistorter output to the RF amplifier input. It means that the operating bandwidth of each element in the chain has to be wide enough to work with the predistorted signal bandwidth which is wider than the undistorted one. Measurements on the final Itelco device will be available soon: a comparison between simulations and the real device performance will be presented in a future work. Moreover, it is our aim to analyse also the BER performance for DAB, DVB and 8VSB systems with and without predistortion.

OUTPUT WITHOUT PREDISTORTER



IBO	6.0 dB
OBO	3.24 dB
IBD (768 KHz from Fc)	-19 dBc
ACI (970 KHz from Fc)	-22 dBc

(a)

OUTPUT WITH PREDISTORTER

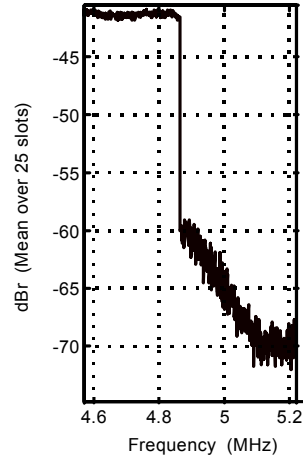

IBO	3.24 dB
OBO	3.45 dB
IBD (768 KHz from Fc)	-19 dBc
ACI (970 KHz from Fc)	-26 dBc

(b)

OUTPUT WITHOUT PREDISTORTER

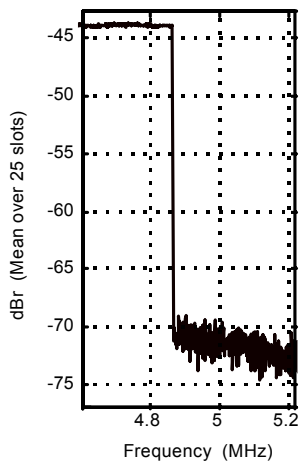

IBO	10.0 dB
OBO	5.979 dB
IBD (768 KHz from Fc)	-26 dBc
ACI (970 KHz from Fc)	-28.5 dBc

(c)

OUTPUT WITH PREDISTORTER

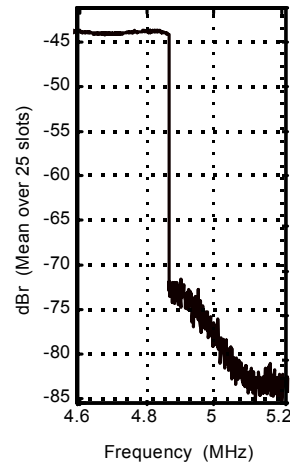

IBO	5.979 dB
OBO	6.015 dB
IBD (768 KHz from Fc)	-29 dBc
ACI (970 KHz from Fc)	-38 dBc

(d)

OUTPUT WITHOUT PREDISTORTER

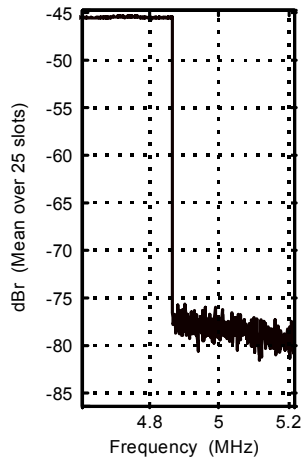

IBO	12.0 dB
OBO	7.678 dB
IBD (768 KHz from Fc)	-32 dBc
ACI (970 KHz from Fc)	-33 dBc

(e)

OUTPUT WITH PREDISTORTER

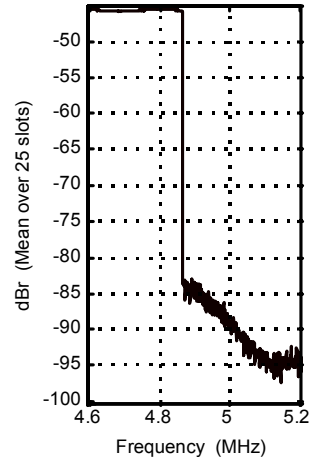

IBO	7.678 dB
OBO	7.685 dB
IBD (768 KHz from Fc)	-39 dBc
ACI (970 KHz from Fc)	-48 dBc

(f)

**Fig.8 (a)(b)(c)(d)(e)(f)** Estimated Amplifier Output with and without Predistorter

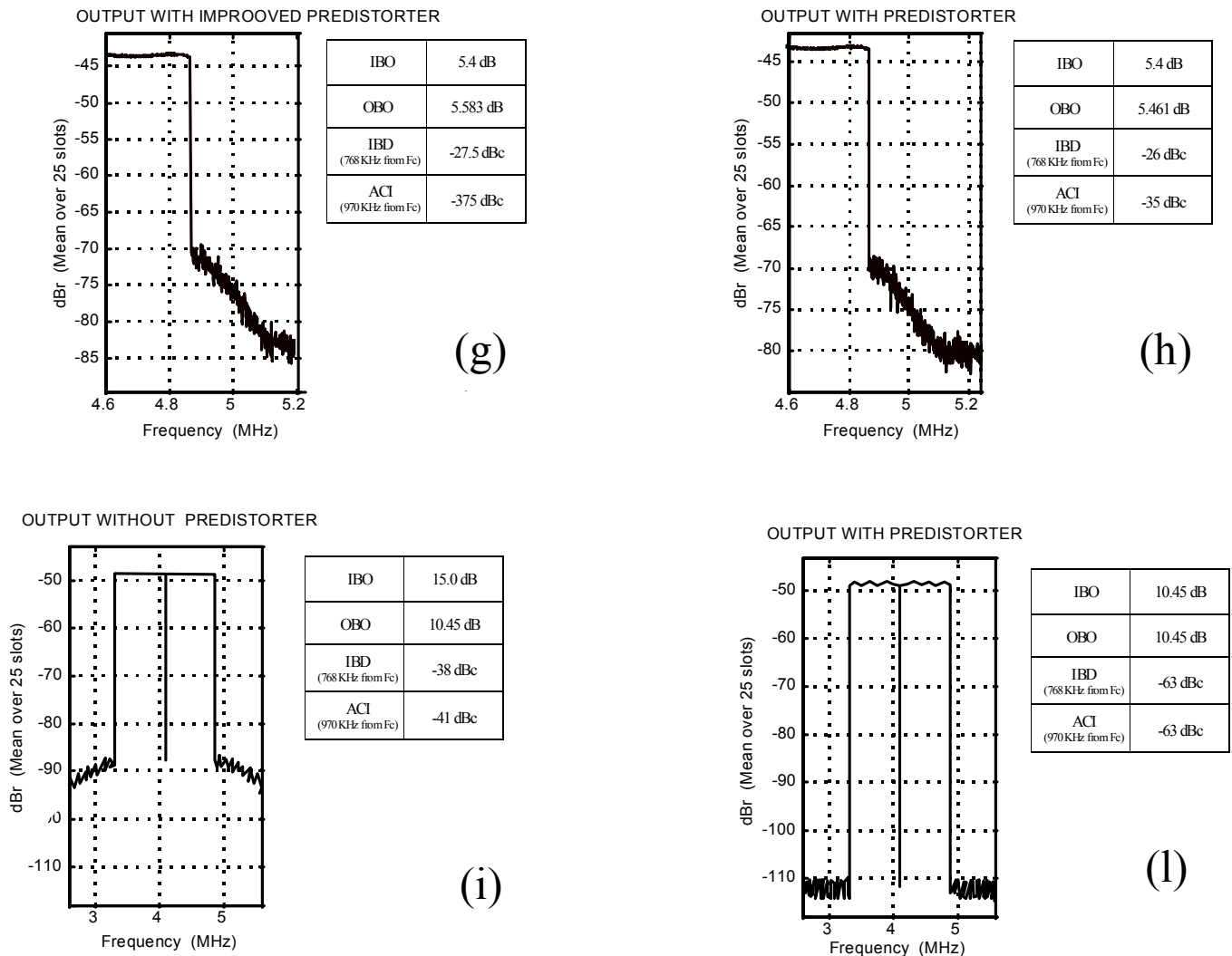

**Fig.8 (e)(g)(g)(h)(i)(l)** Estimated Amplifier Output with and without Predistorter

**References**

[1] S.Kumar and G.Wells “Memory Controlled Feedforward Lineariser Suitable for MMIC Implementation”, *IEE Proceedings-H.*, Vol. 138, No. 1, pp. 9-12, February 1991.

[2] J.K.Cavers “Adaptation Behaviour of a Feedforward Amplifier Linearizer”, *IEEE Transactions on Communications*, Vol. 44, No. 1, pp. 31-40, February 1995.

[3] G.Karam and H.Sari “A Data Predistortio Technique with Memory for QAM Radio Systems”, *IEEE Transactions on Communications*, Vol. 39, No. 2, pp. 336-344, February 1991.

[4] G.Lazzarin, S.Pupolin, and A.Sarti “Non Linear Compensation in Digital radio Systems”, *IEEE Transactions on Communications*, Vol. 42, No. 2/3/4, pp. 988-999, April 1994.

[5] A.R. Kaye, D.A. George, and M.J. Eric, “Analysis and Compensation of Bandpass Nonlinearity for Communications”, *IEEE Transactions on Communications*, pp. 965-672, October 1972.

[6] A.A.M.Saleh and J.Salz. “Adaptive Linearisation of Power Amplifiers in Digital Radio Systems”, *The Bell System Technical Journal*, Vol. 62, No. 4, pp. 1019-1033, April 1983.

[7] J.K.Cavers, “Amplifiers Linearization Using a Digital Predistorter with Fast Adaptation and Low Memory Requirements”, *IEEE Transactions on Vehicular Technology*, Vol. 39, No. 4, pp. 374-382, November 1990.

[8] J.A.C.Bingham, “Multicarrier Modulation for Data Transmission : An Idea Whose Time has Come”, *IEEE Communications Magazine*, pp. 514, May 1990.

[9] L. Cimini, “Analysis and Simulation of a Digital Mobile Channel using Orthogonal Frequency Division Multiplexing”, *IEEE Transactions on Communications*, vol. COM-33, pp. 665-675, July 1985.

[10] A. Papoulis, “Probability, Random Variables and Stochastic Processes” McGraw Hill, New York, 1965

[11] M.Schilpp et al. “Influence of Oscillator Noise and Clipping on



OFDM for Terrestrial Broadcasting of Digital HDTV”, IEEE International Conference on Communications (ICC ’95), Seattle, USA, pp. 1678-1682.

[12] J. Rinne, and M. Renfors, “The Behaviour of Orthogonal Frequency Division Multiplexing Signals in Amplitude Limiting Channel”, IEEE International Conference on Communications (ICC ’94), New Orleans, USA, pp. 381-385.

[13] ETS 300 401, “Radio Broadcasting Systems; Digital Audio Broadcasting (DAB) to mobile portable and fixed receivers”, February 1995, pp180.



**Sante Andreoli** was born on November 1, 1958. He was graduated Summa Cum Laude in Electronic Engineering at Polytechnic of Turin (1982) with a dissertation on "Design For Testability". After 2 years working for a Research at Polytechnic of Turin and on microprocessor applications, he joined Alcatel-Telettra S.p.A as Designer in the Military Telecommunications Division. In 1992 he

became Design Manager at R&D Siemens-Italtel laboratories. In 1994 he finally joined ITELCO as responsible of the Signal Processing Laboratories and Product Manager for DAB and DVB equipment. He is author of several patented inventions and technical papers.



**Paolo Banelli** was born in Perugia, Italy, on May 19, 1968. He is currently attending the 3rd year of the Ph.D. Course in Electronics Engineering- Telecommunications at the University of Perugia where he received the Laura Degree “Summa cum Laude” in Electronics Engineering in 1993. His research interests are Non-Linear Distortions, Broadcasting and Mobile Communications.

.He is an IEEE Student Member.



**Saverio Cacopardi** received his Degree in Electrical Engineering in 1970, from the University of Rome, Italy. From 1971 to 1975 he was employed by SIP (Italian Telephone Operating Company), working on in the PCM transmission and CATV fields. In 1975 he joined the Electrical Communication Department of the University of Rome as an assistant professor. From 1979 to 1985 he was

associate professor of Electrical Communications at the University of Ancona. From 1986 to 1991 he was associate professor of radio aids to navigation at the University “La Sapienza” of Rome. In 1991 he joined the University of Perugia as an associate professor of electrical communications. His current research activity is in Mobile Communications, WLAN and Broadcasting. He is an IEEE member.



**Howard G. McClure** Product manager, Visual Electronics, NY, NY 1966-69 where he directed the development of first IF modulated TV transmitter in the USA. 1969-72 TV Project Manager, Harris Corp. Quincy IL where he was responsible for the development of the first 220 kW UHF TV transmitter. 1972-79 Vice President of Electronics, Lenco Inc, Jackson MO where he led the development of modular test equipment for the TV industry.

1985-94 President, McClure Consulting Services, consulting to the International and Domestic Broadcasting Industry. Joined Itelco USA

in October 1994 as VicePresident, North American operations. He is a member of the IEEE and the BTS Administrative committee.